

AVERETT SEPTIC TANK CO. INC.

1-863-665-1748

6.0" WALL

900 GAL TANK CAT. 4

LEGEND # 53-037-06D

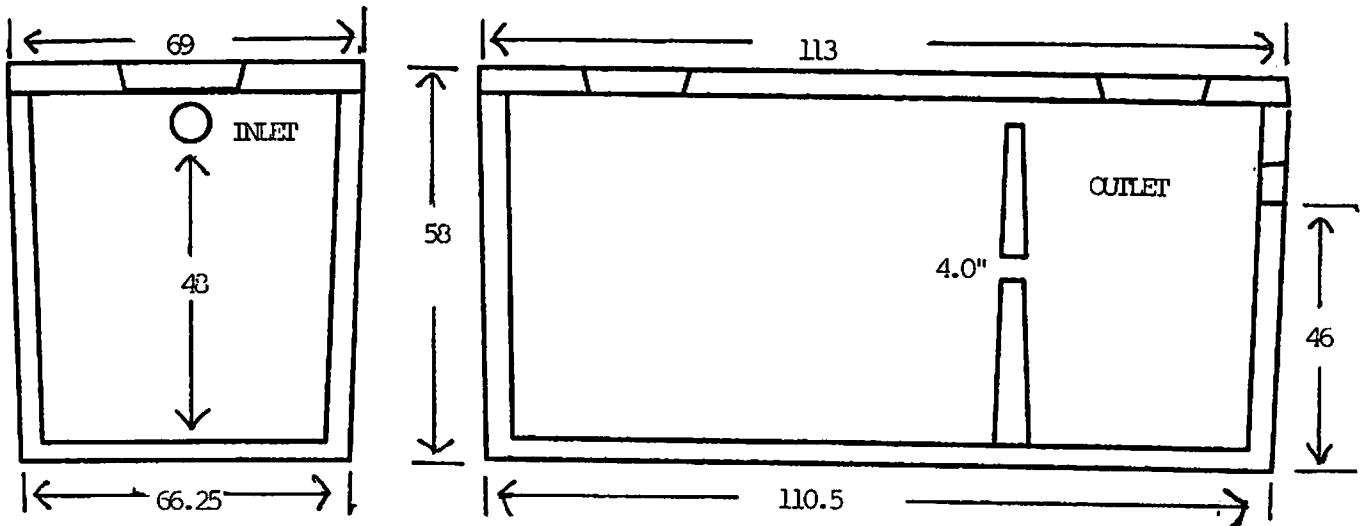

TANK INFORMATION: 900 DUAL COMPARTMENT TANK CAT 4, WITH SLIDE IN BAFFLE, 6.0" WALLS AND BOTTOM, CONSTRUCTED WITH STEEL AND FIBER REINFORCED CONCRETE AT A MINIMUM OF 4500 PSI. TANK CAN BE CONVERTED TO A SINGLE COMPARTMENT.

LIDS: 8" LID WITH 2-24" OCTOGON OPENINGS

WEIGHT: CAT 4 TANK = SEE 1250 6" WALL
CAT 4-8" LID = SEE 1260 6" WALL

INLET & OUTLET: 4" HOLES

TANK & LIDS: PLEASE ALLOW 3 WEEKS FOR MANUFACTURE. TANK REQUIRES 28 DAYS TO CURE.

THIS TREATMENT RECEPTACLE IS ENGINEERED AND TESTED BY THE DEPT. OF HEALTH IN ACCORDANCE WITH CHAPTER 64E-6.013, OF THE FLORIDA ADMINISTRATIVE CODE (FAC) DATED MARCH 22, 2000.

DRAWING NOT TO SCALE